

# Original BMW Parts and Accessories.

## Installation Instructions.



### BMW WaterBlade Retrofit.

**BMW 5 Series Saloon (G30)**

**BMW 5 Series Touring (G31)**

**BMW 7 Series Saloon (G11, G12)**

#### Retrofit kit number

61 61 5 A12 1A0 BMW WaterBlade kit

#### Installation time

The installation time is **approx. 0.5 hour**. This may vary depending on the condition of the car and its equipment package.

#### Important information

These installation instructions are primarily designed for use within the BMW dealership organisation and by authorised BMW service companies.

These installation instructions are intended for use by qualified specialist staff trained on BMW cars with the relevant expert knowledge.

All work must be completed using the latest BMW repair manuals, wiring diagrams, servicing manuals and work instructions, in a logical order, using the prescribed tools (special tools), and observing current health and safety regulations.

**If you experience installation or functional problems, restrict troubleshooting to approx. 0.5 hours for mechanical work and 1.0 hour for electrical work.**

To avoid unnecessary extra work and/or costs, please send an inquiry to the technical parts support team.

Quote the following information:

- VIN,
- retrofit kit part number,
- a detailed description of the problem,
- any work already carried out.

Please do not archive the printout of these installation instructions. The current version can be found in the EPC.

#### Pictograms

 Denotes instructions that draw your attention to dangers.

 Denotes instructions that draw your attention to special features.

◀ Denotes the end of the instruction or other text.

#### Installation information

All illustrations show LHD cars; proceed in the same way on RHD cars.

| Section                                | Page |
|--|------|
| 1. Parts list .....                    | 3    |
| 2. Preparatory work .....              | 4    |
| 3. Installing the BMW WaterBlade ..... | 5    |
| 4. Concluding work and coding .....    | 12   |

# 1. Parts list

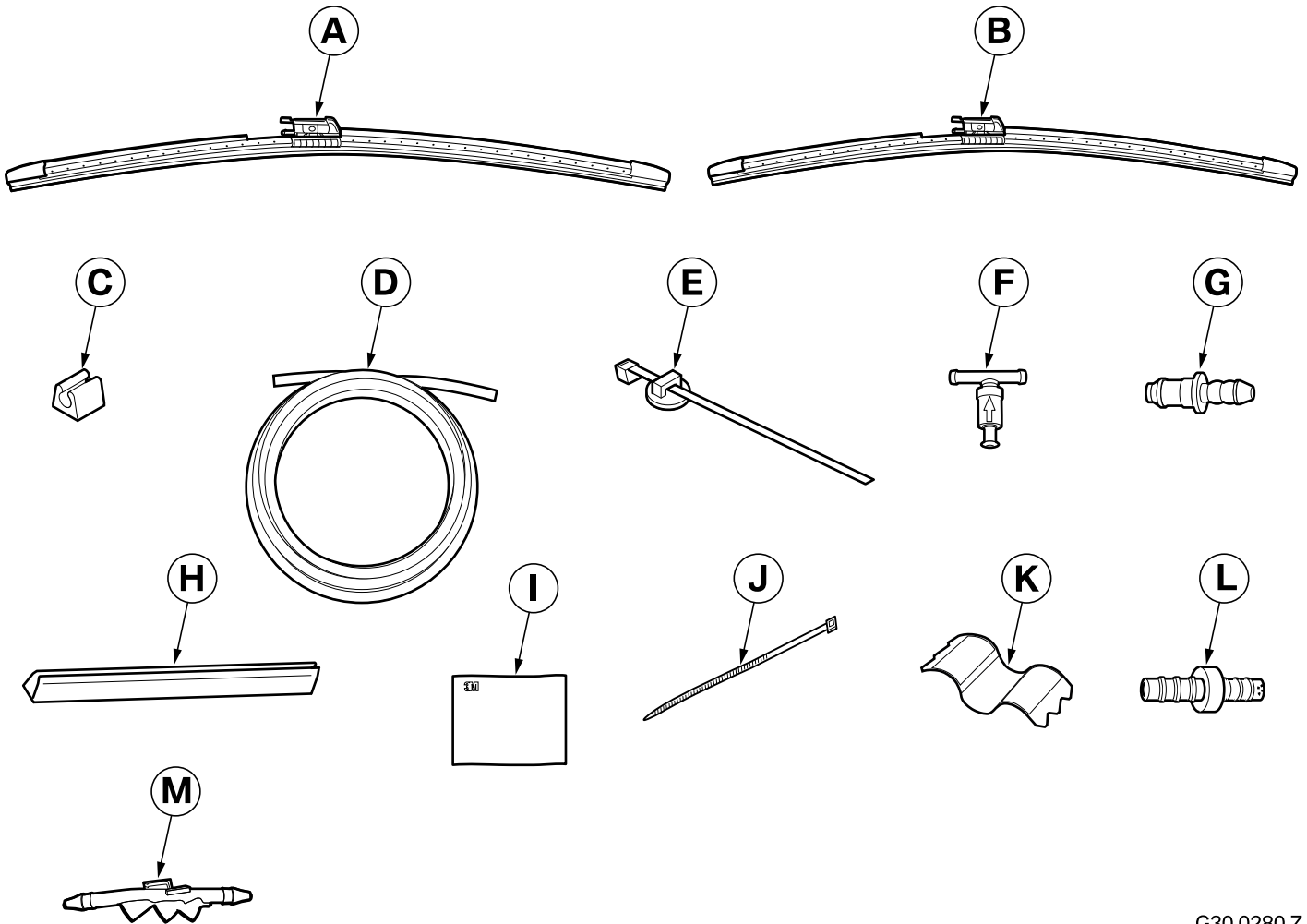

G30 0280 Z

## Legend

- A** WaterBlade, driver's side
- B** WaterBlade, passenger's side
- C** Adhesive holder (6 x)
- D** 4000 mm hose
- E** Cable tie with holder (6 x)
- F** T joint with non-return valve
- G** Connector without non-return valve
- H** Wiper arm hose holder (4 x)
- I** Cleaning cloth (2 x)
- J** Cable ties (6 x)
- K** Hose clamp (2 x)
- L** Reducer piece
- M** 3-way nozzle

## 2. Preparatory work

|  | ISTA/AIR No. |
|--|--------------|
| Instructions for handling the documents: Repair manual, technical data, tightening torques | 00 11 ...    |
| <b>The following components must be removed first of all</b>                               |              |
| Both wiper blades (no longer required)   | 61 61 041    |
| Front cowl panel cover   | 51 13 ...    |

### 3. Installing the BMW WaterBlade

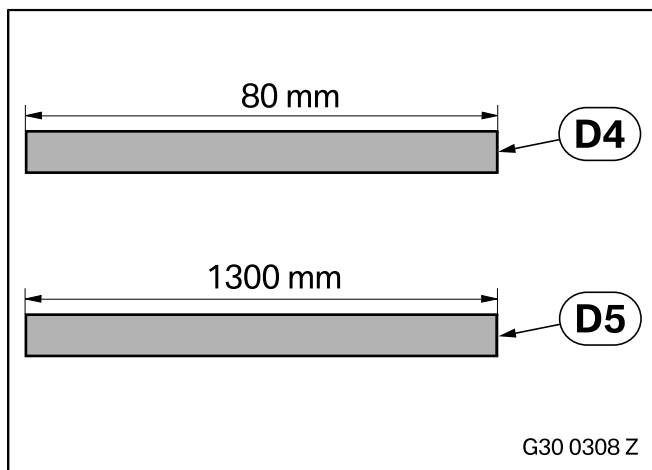
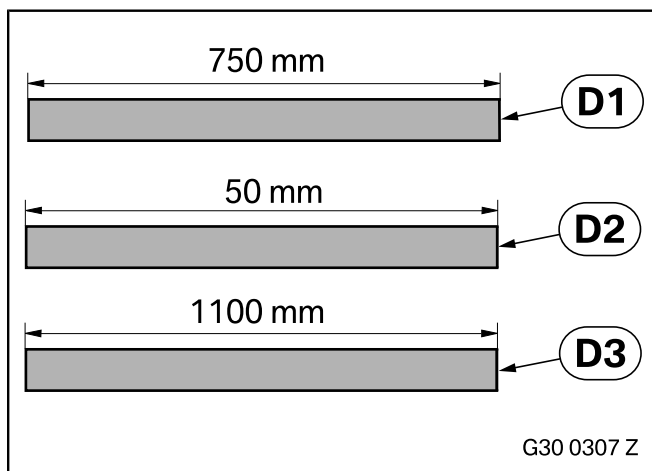
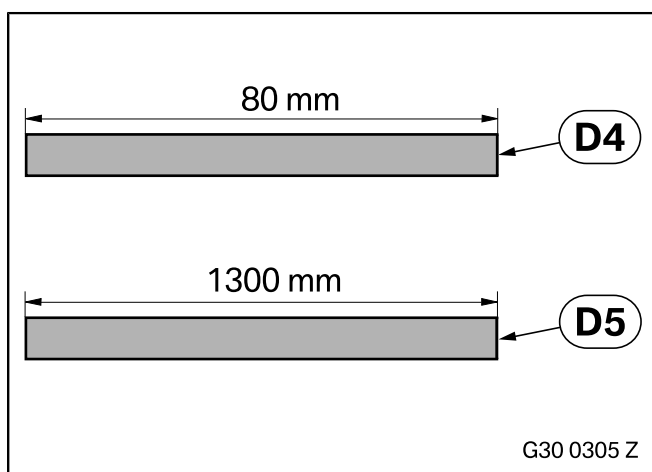
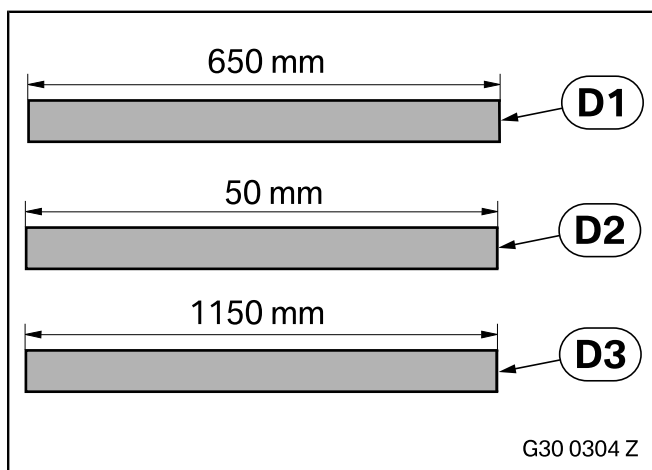

#### For G30 and G31 only

Cut the hoses **D1-D3** to length using standard workshop equipment out of hose **D** as shown.

- Connect hose **D1** from the WaterBlade on the driver's side **A** to the non-return valve **L**
- Connect hose **D2** from the WaterBlade on the passenger's side **B** to the 3-way nozzle **M**
- Connect hose **D3** from the 3-way nozzle **M** to the T joint with non-return valve **F**

Cut the hoses **D4** and **D5** to length using standard workshop equipment out of hose **D** as shown.

- Connect hose **D4** from the reducer piece **L** to the T joint with non-return valve **F**
- Connect hose **D5** from the T joint with non-return valve **F** to the quick-release fastening on the car

#### For G11 and G12 only

Cut the hoses **D1-D3** to length using standard workshop equipment out of hose **D** as shown.

- Connect hose **D1** from the WaterBlade on the driver's side **A** to the non-return valve **L**
- Connect hose **D2** from the WaterBlade on the passenger's side **B** to the 3-way nozzle **M**
- Connect hose **D3** from the 3-way nozzle **M** to the T joint with non-return valve **F**

Cut the hoses **D4** and **D5** to length using standard workshop equipment out of hose **D** as shown.

- Connect hose **D4** from the reducer piece **L** to the T joint with non-return valve **F**
- Connect hose **D5** from the T joint with non-return valve **F** to the quick-release fastening on the car

### 3. Installing the BMW WaterBlade

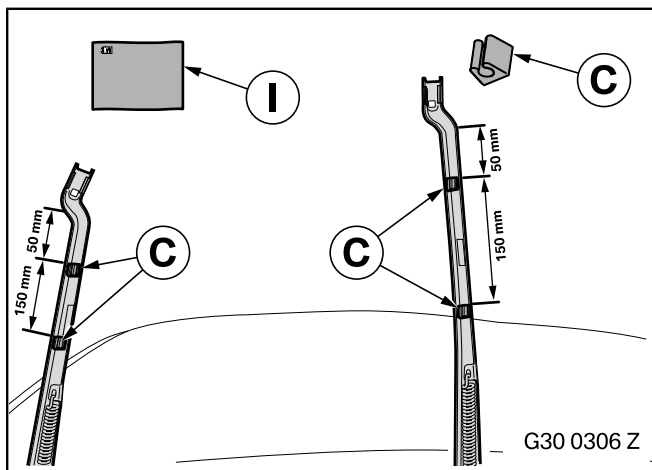

#### All cars

- ▷ Clean the bonding surfaces on the inside of the wiper arms with the cleaning cloth **I** so that they are grease-free. ◀
- ▷ To ensure that the adhesive bonds as well as possible, pre-heat the wiper arms to a temperature of around 40 °C using a hot air blower (hand warm). ◀
- ⚠ It is essential that you press the adhesive holders **C** for 30 seconds each to ensure that the adhesive bonds perfectly. ◀

Remove the adhesive backing film from adhesive holder **C**.

Bond the adhesive holders **C** to the insides of the wiper arms using the dimensions shown and press them into position for 30 seconds using the maximum pressure you can generate without tools.

- ▷ The illustration shows the left-hand side of the car. Proceed in the same way on the right-hand side. ◀

Connect the hose **D1** as shown to the WaterBlade on the driver's side **A**.

Install the WaterBlade **A** as described in **ISTA/AIR repair manual 61 61 041**.

Do not clamp the hose **D1** in the adhesive holders **C** yet.

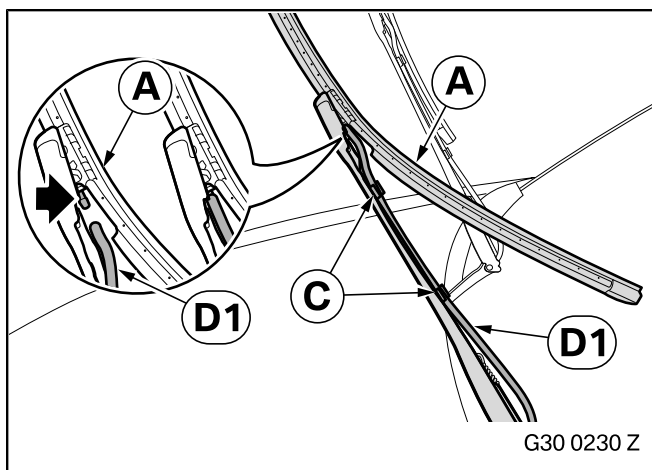

- ▷ The illustration shows the right-hand side of the car. ◀

- ▷ Ensure that the spray nozzles on the 3-way nozzle **M** are directed at the windscreen. ◀

Connect the hose **D2** as shown to the WaterBlade on the passenger's side **B**.

Install the WaterBlade **B** as described in **ISTA/AIR repair manual 61 61 041**.

Connect the hose **D2** as shown to the 3-way nozzle **M**.

Connect the hose **D3** as shown to the 3-way nozzle **M**.

Do not clamp the hose **D3** in the adhesive holders **C** yet.

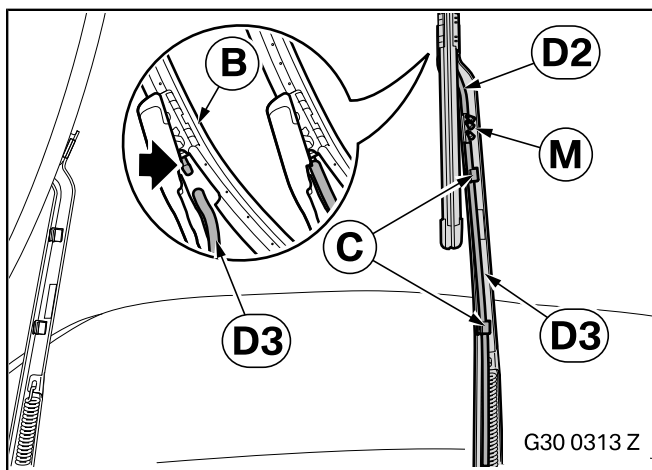

### 3. Installing the BMW WaterBlade

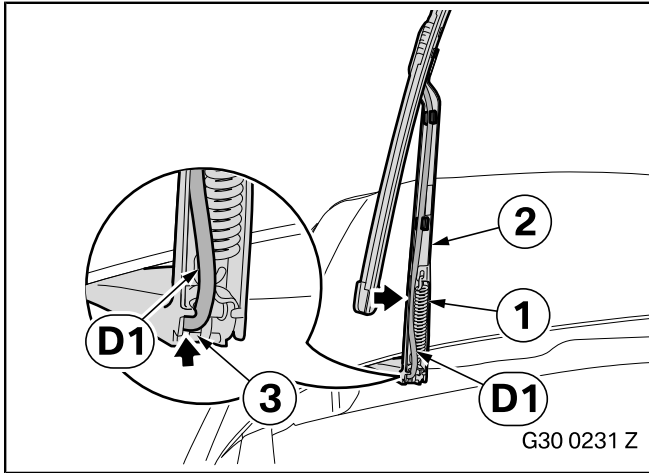

▶ The illustration shows the left-hand side of the car. Proceed in the same way on the right-hand side. ◀

Clamp hose **D1** between the spring (1) and wiper arm (2) as shown using a blunt tool.

Thread hose **D1** through the opening (3) as shown and route it to the front cowl panel cover.

### 3. Installing the BMW WaterBlade

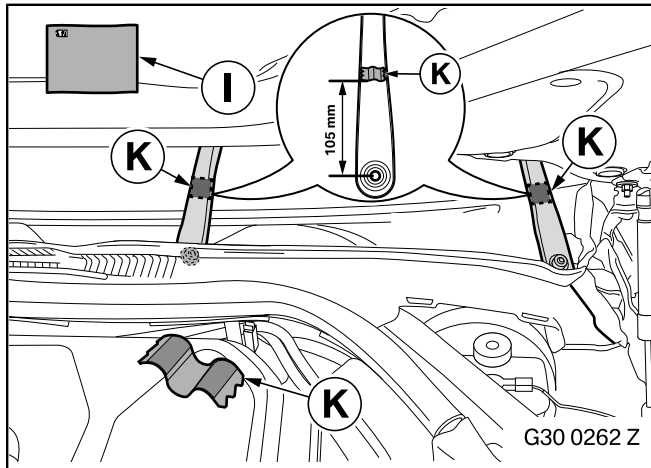

☐ Clean the bonding surfaces on the inside of the wiper arms with the cleaning cloth **I** so that they are grease-free. ◀

☐ To ensure that the adhesive bonds as well as possible, pre-heat the wiper arms to a temperature of around 40 °C using a hot air blower (hand warm). ◀

⚠ It is essential that you press each hose clamp **K** for 30 seconds to ensure that the adhesive bonds perfectly. ◀

Remove the backing film from the hose clamp **K**.

Bond the hose clamp **K** using the dimensions shown from the centre of the screw-on point of the wiper arms to the bottom edge of the hose clamp **K** on the insides of the wiper arms and press them into position for 30 seconds using the maximum pressure you can generate without tools.

Route hoses **D1** and **D3** through the opening in the hose clamps **K** and to the front cowl panel cover as shown.

Drill through the marked drilling point (1) on the rear rubber lip of the front cowl panel cover from the front using the dimensions shown with a 6.5 mm drill bit.

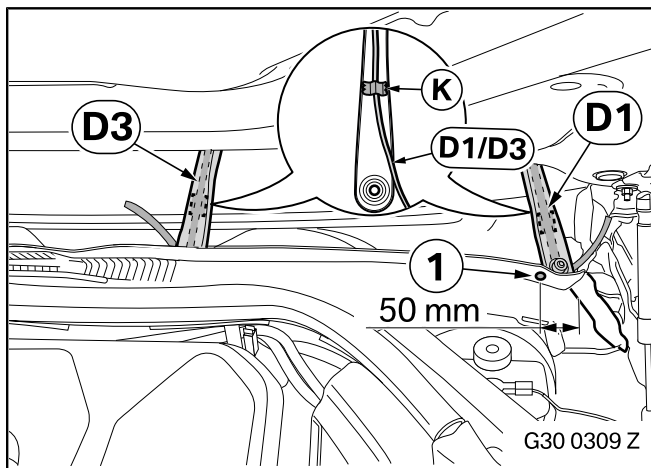

### 3. Installing the BMW WaterBlade

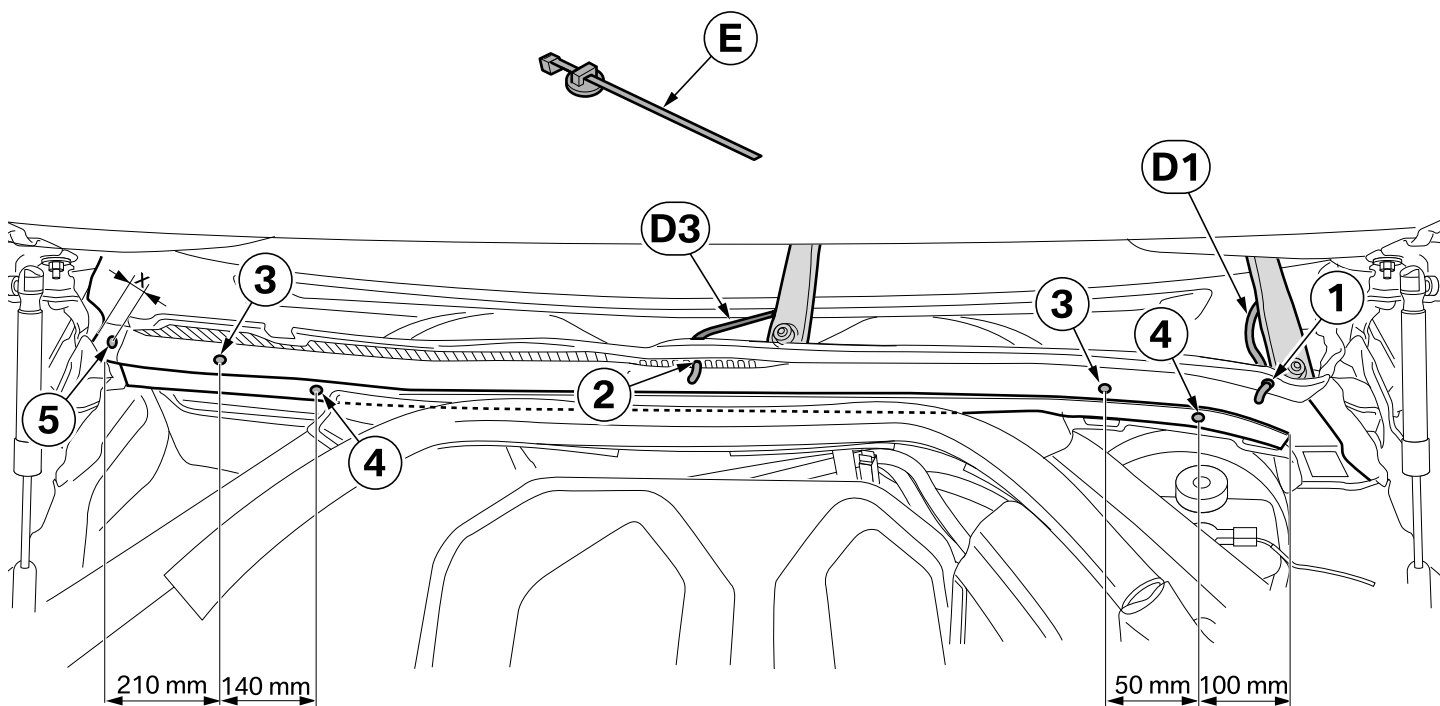

G30 0310 Z

Make sure that no cables, electronic components or metal parts behind drilling point are damaged when you drill the holes. ◀

When routing them, ensure that hoses **D1** and **D3** have enough freedom of movement, are not near any moving parts and cannot be kinked or crushed. ◀

Thread hose **D1** through the hole (1) as shown.

Thread hose **D3** through the sixth opening in the front cowl panel cover (2) as shown.

Drill through the marked drilling points (3) on the front cowl panel cover from above using the dimensions shown with a 6.5 mm drill bit and deburr it.

Drill through the marked drilling points (4) on the front rubber lip of the front cowl panel cover from the front using the dimensions shown with a 6.5 mm drill bit.

Drill through the marked drilling point (5) on the side of the front cowl panel cover using dimension **x** with a 6.5 mm drill bit.

– G11, G12: **x** = 30 mm

– G30, G31: **x** = 40 mm

Insert cable ties with holder **E** into the drilled holes (3) and press them firmly into place.

### 3. Installing the BMW WaterBlade

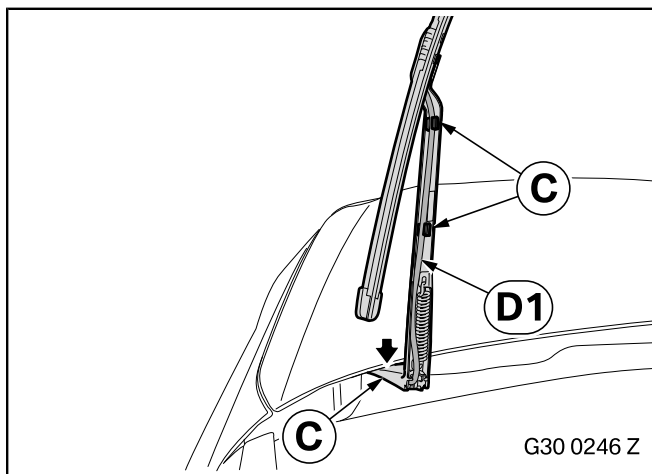

▶ The illustration shows the left-hand side of the car. Proceed in the same way on the right-hand side. ◀

Clamp hoses **D1** and **D3** in adhesive holders **C** as shown.

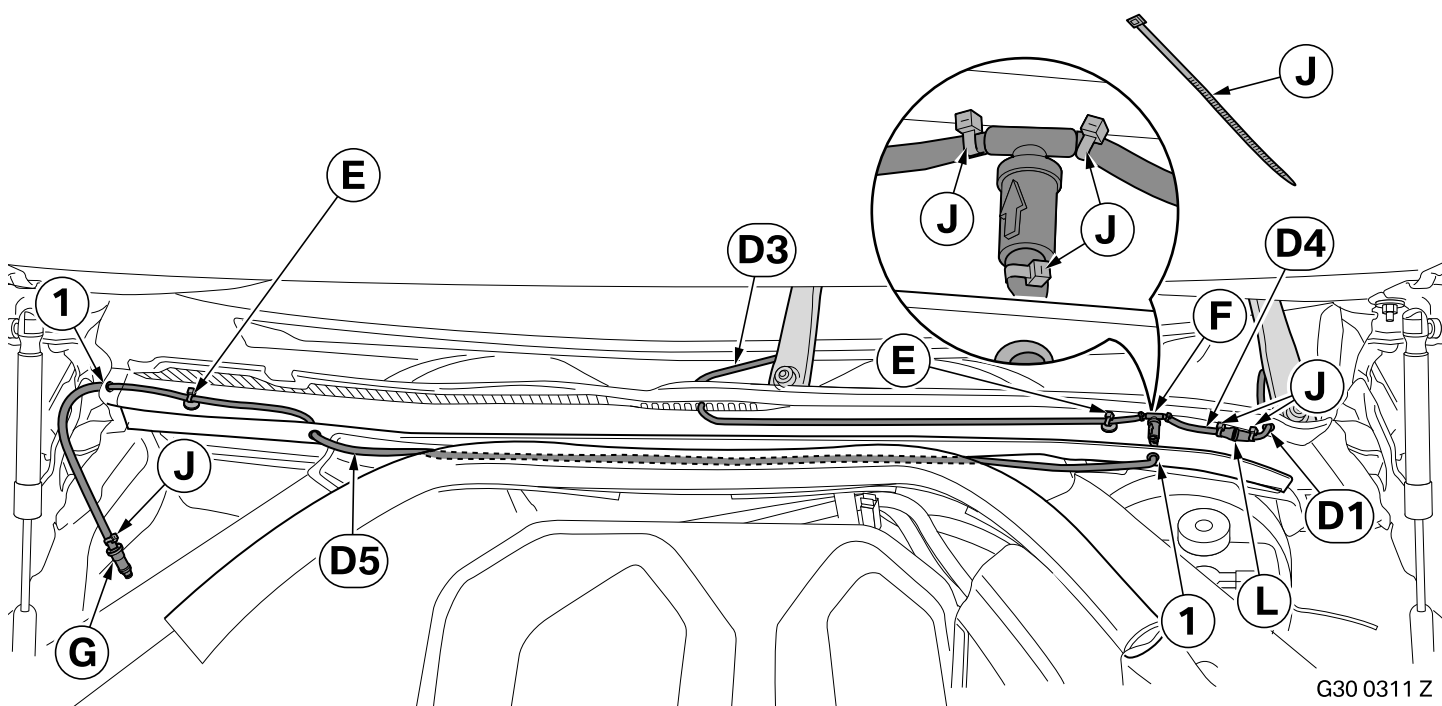

▶ When routing them, ensure that hoses **D1**, **D3** and **D4** have enough freedom of movement, are not near any moving parts and cannot be kinked or crushed. Adjust the hose lengths if necessary. ◀

Route hose **D1** as shown to the location of the reducer piece **L**, moisten it with lubricant, connect it to the reducer piece **L** and secure it with a cable tie **J**.

Route hose **D3** as shown to the location of the T joint with non-return valve **F**, moisten it with lubricant, connect it to the T joint with non-return valve **F** and secure it with a cable tie **J**.

Moisten hose **D4** with lubricant, connect it to the T joint with non-return valve **F** and reducer piece **L** and secure it with a cable tie **J**.

Thread hose **D5** through the hole (1), moisten it with lubricant, connect it to the T joint with non-return valve **F**, secure it with a cable tie **J** and route it to the location of the quick-release fastening on the car.

Secure hoses **D3** and **D5** to the cable tie with holder **E**.

Moisten the connector without non-return valve **G** with lubricant, insert it into hose **D5** and secure it with a cable tie **J**.

### 3. Installing the BMW WaterBlade

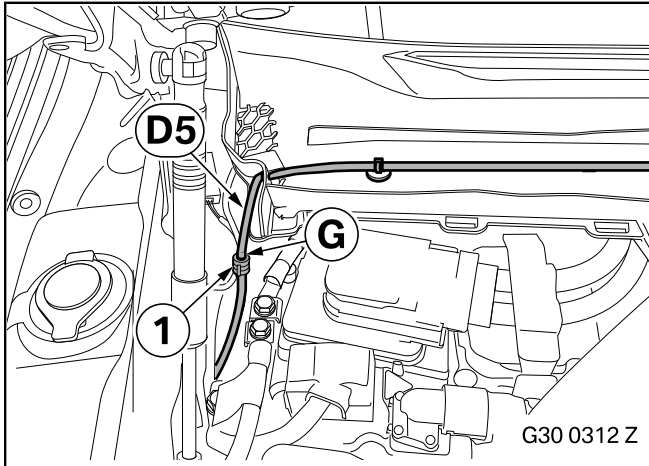

Release the quick-release fastening on the car's nozzle chain and remove the connector. The nozzle chain is no longer required.

Insert the connector without non-return valve **G** into the car's quick-release fastening (1) and lock it.

Secure hose **D5** in a suitable place using standard workshop equipment to ensure access to the bonnet hinge.

## 4. Concluding work and coding

The retrofit system does not require programming/coding.

- Re-assemble the car
- Conduct a visual inspection of the lines for kinks, chafing points and sagging sections (on the wiper arm by wiggling them)
- Check that the WaterBlade functions correctly and does not leak